

## THE TERNARY SYSTEM SILVER–ANTIMONY–TELLURIUM. STUDY OF THE SUBTERNARY $\text{Sb}_2\text{Te}_3$ – $\text{Ag}_2\text{Te}$ –Te

R M MARIN-AYRAL, B LEGENDRE \*, G BRUN, B LIAUTARD and J C TEDENAC

*Laboratoire de Physicochimie des Matériaux Solides U A 407, USTL Place E,  
Bataillon 34060 Montpellier (France)*

(Received 3 November 1987)

### ABSTRACT

The  $\text{Sb}_2\text{Te}_3$ – $\text{Ag}_2\text{Te}$ –Te subternary system was investigated using thermal analysis, differential scanning calorimetry metallographic techniques and X-ray powder analysis. Three isopleth sections were constructed. The transitory reactions were characterized and the eutectic point coordinates were determined. Analysis of polythermal projection of this system is given.

### INTRODUCTION

The study of this system is interesting because of thermoelectric conversion devices. This system includes an intermediate phase  $\langle \text{Ag}_{19}\text{Sb}_{29}\text{Te}_{52} \rangle$  (or  $\langle \text{Ag}_4\text{Sb}_6\text{Te}_{11} \rangle$ ) which has a very low thermal conductivity ( $K = 0.6 \text{ W K}^{-1} \text{ m}^{-1}$ ) and hence is interesting for thermoelectric applications.

In spite of many studies on this compound [1–3] the results are not satisfactory for applications. Thus, we have reinvestigated this compound and its physical behaviour. Because of the complexity of crystal growth, studies on the ternary system were found to be necessary. In the first stage of this work we have investigated the subternary system  $\text{Sb}_2\text{Te}_3$ – $\text{Ag}_2\text{Te}$ –Te.

Thermal analysis by heating, differential scanning calorimetry, microprobe analysis and X-ray diffraction were used.

### EXPERIMENTAL

For each alloy of composition  $\text{Ag}_x\text{Sb}_y\text{Te}_z$ , silver, antimony and tellurium metals were mixed and heated in quartz ampoules under a vacuum of  $10^{-4}$ .

---

\* Laboratoire de Chimie Minérale Faculté de Pharmacie, Rue J B Clément, 92290 Chatenay Malabry (France)

torr The heat treatment adopted for each composition was chosen as follows (i) heating of the mixture at 973 K for 12 h; (ii) stacking and cooling of the alloys to room temperature, (iii) annealing at 573 K for 21 days

After this thermal treatment each sample was characterized by radiocrystallographic measurements Thermal analysis was carried out with an instrument constructed in our own laboratory [4] Several samples in the medium range of the ternary system were also studied with a Netzsch apparatus. Calorimetric analysis was carried out with a DSC Setaram in order to verify thermal analysis data. Characterization of the alloys was performed by optical metallography and the chemical composition determined by microprobe analysis

### CONSTITUTIVE BINARY SYSTEMS

This subternary system is built up from the cross sections  $\text{Sb}_{0.4}\text{Te}_{0.6}$ – $\text{Ag}_{0.666}\text{Te}_{0.333}$ ,  $\text{Sb}_{0.4}\text{Te}_{0.6}$ – $\text{Te}$ ,  $\text{Ag}_{0.666}\text{Te}_{0.333}$ – $\text{Te}$  which have been studied previously

#### *Sub-system $\text{Sb}_{0.4}\text{Te}_{0.6}$ – $\text{Te}$ (Fig 1)*

The Sb–Te phase diagram has been studied by several groups [5–10] and particularly, by Hansen [10]. After a study of the  $\delta$  phase  $\text{Sb}_{0.4}\text{Te}_{0.6}$ , this diagram was modified by Abrikosov et al [11] This work was reinvestigated by Bordas and Legendre [12] who have determined mixed enthalpies and the behaviour of  $\Delta H$  of the  $\delta$  phase as a function of  $T$  [13,14] These authors have shown the chemical formula of this compound to be  $\langle \text{Sb}_{0.405}\text{Te}_{0.595} \rangle$  This phase reveals a defect in tellurium in relation to the well-known stoichiometric formula of this compound ( $\text{Sb}_2\text{Te}_3$ )

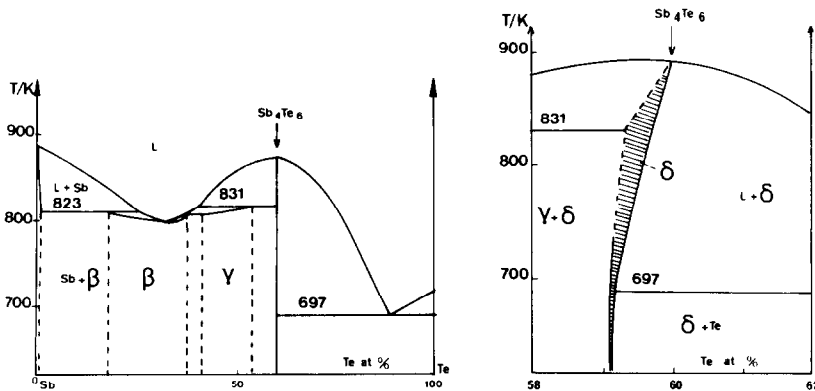
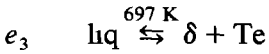

Fig 1 Phase diagram of the Sb–Te system

The characteristics of this system are (i) fusion temperature of the  $\delta$  phase 889 K; (ii) eutectic reaction at 697 K according to



### Sub-system $\text{Ag}_{0.666}\text{Te}_{0.333}-\text{Te}$

The Ag-Te system has been studied by Kracek et al [15] and re-determined by Legendre [16]. It shows three intermediate compounds in the part of the diagram applicable to our work (Fig 2). There are two incongruent phases of formulae ( $\langle \text{Ag}_{0.625}\text{Te}_{0.375} \rangle$  and  $\lambda$ ) and one congruent phase

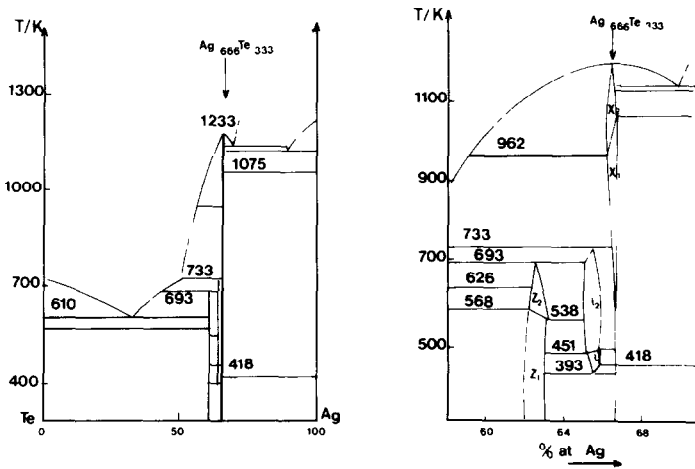
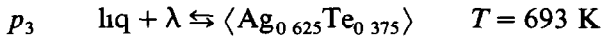
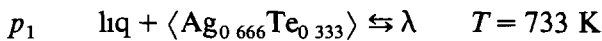
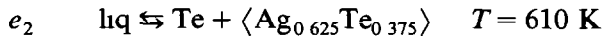

Fig 2 Phase diagram of the Ag-Te system

Moreover, it has been determined that the  $\lambda$  phase exists only above 393 K. The reactions for by these phases are



### Sub-system $\text{Sb}_{0.4}\text{Te}_{0.6}-\text{Ag}_{0.666}\text{Te}_{0.333}$ (Fig 3)

This system was studied in our laboratory [17]. An intermediate phase with a peritectic fusion is formed around the composition  $\text{Ag}_{0.19}\text{Sb}_{0.29}\text{Te}_{0.52}$ . The invariants are

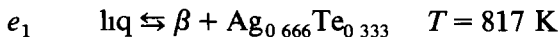

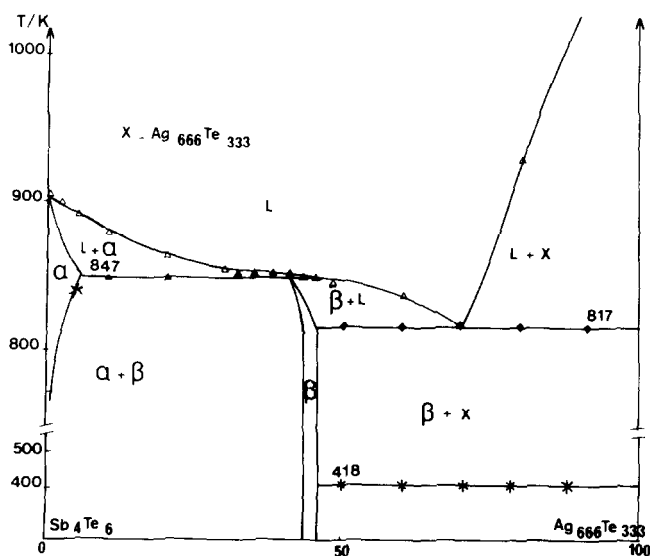

Fig 3 Phase diagram of the quasi-binary system  $\text{Sb}_2\text{Te}_3$ - $\text{Ag}_2\text{Te}$

#### THE SUBSYSTEM $\text{Sb}_{0.4}\text{Te}_{0.6}$ - $\text{Ag}_{0.666}\text{Te}_{0.333}$ -Te

Three isoplethal sections have been studied in the subsystem  $\text{Sb}_2\text{Te}_3$ - $\text{Ag}_2\text{Te}$ -Te. The reactions that take place in the constituent binaries and in the ternary system are summarized in Table 1.

#### *Isoplethal sections*

These sections are plotted in Figs 4-6. Experimental points were determined by DTA and DSC measurements during heating. The first section corresponds to the  $\langle \text{Sb}_{0.4}\text{Te}_{0.6} \rangle$ - $\langle \text{Ag}_{0.45}\text{Te}_{0.55} \rangle$  system and the second corresponds to the  $\langle \text{Sb}_{0.4}\text{Te}_{0.6} \rangle$ - $\langle \text{Ag}_{0.2}\text{Te}_{0.8} \rangle$  system. Two invariants are obtained at 605 and at 633 K. The first is the path of the ternary eutectic valley. The *b* point coordinates have been determined with an accuracy of 5%. The Tamman effects show a maximum for this point *b*. Its coordinates are  $\text{Ag}_{0.37}\text{Sb}_{0.07}\text{Te}_{0.56}$ . Another invariant reaction takes place at 633 K and point *a* corresponds to the composition  $\text{Ag}_{0.35}\text{Sb}_{0.09}\text{Te}_{0.56}$ .

In this system, the thermal effects indicative of the paths of the tie lines are very weak. They correspond to very small energies. The general shape of section 2 is similar to that of section 1, and thus similar comments can be made about the precision of the coordinates and paths of the tie lines. Also two invariant reactions (at points *a'* and *b'*) (one eutectic and one peritectic) exist in this section for 605 and 633 K. The coordinates of point *a'* are  $\text{Ag}_{0.13}\text{Sb}_{0.13}\text{Te}_{0.74}$  and those of point *b'* are  $\text{Ag}_{0.14}\text{Sb}_{0.11}\text{Te}_{0.75}$ . The ternary eutectic point is surrounded by these sections. Its position has been calcu-

TABLE I

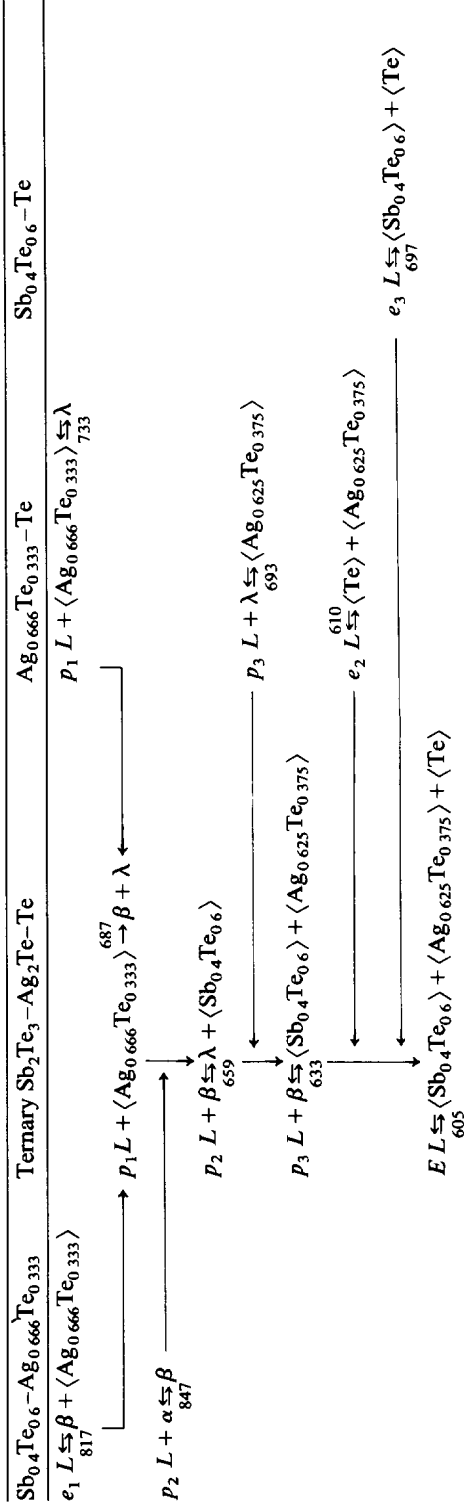
The reaction path in the  $Sb_2Te_3-Ag_2Te-Te$  system

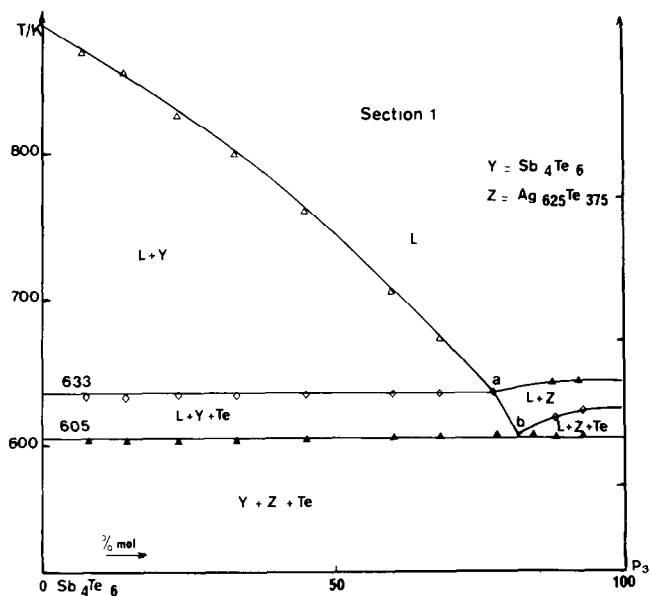

Fig 4 Isolethal section  $\text{Sb}_{0.4}\text{Te}_{0.6}-\text{Ag}_{0.45}\text{Te}_{0.55}$

lated from the coordinates of the points  $a$ ,  $b$ ,  $a'$ ,  $b'$  (Figs 4 and 5) According to the method reported in ref 18

$$E \begin{cases} \text{Ag} = 0.15 \\ \text{Sb} = 0.12 \\ \text{Te} = 0.73 \end{cases}$$

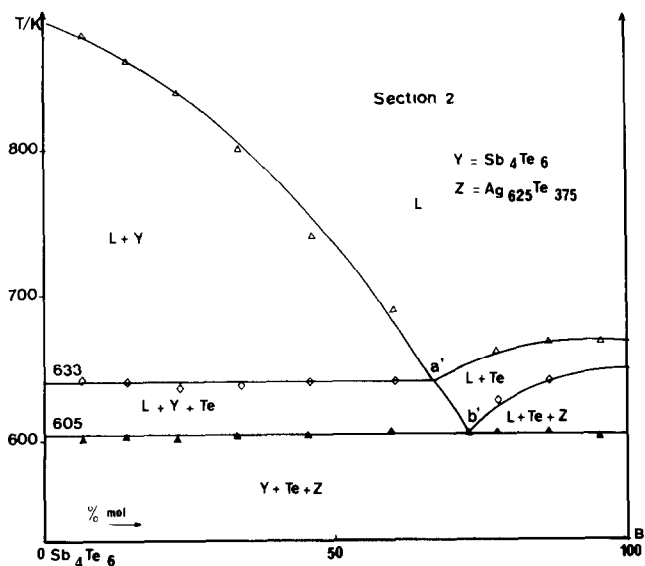

Fig 5 Isolethal section  $\text{Sb}_{0.4}\text{Te}_{0.6}-\text{Ag}_{0.2}\text{Te}_{0.8}$

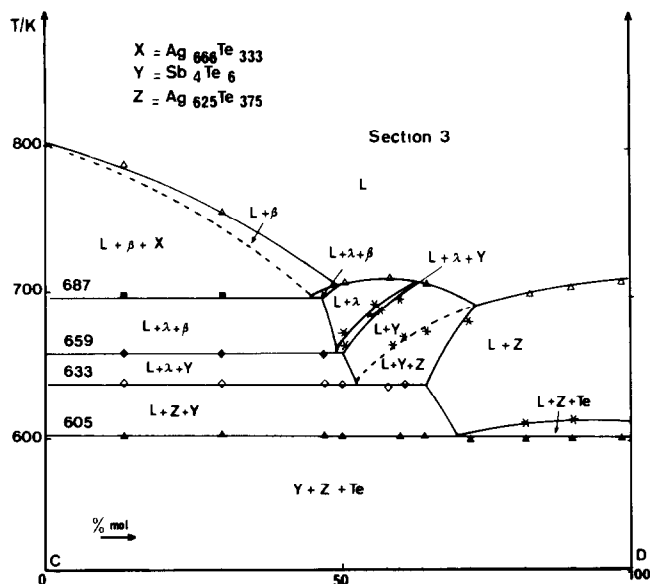

Fig 6 Isolethal section  $\text{Ag}_{0.42}\text{Sb}_{0.14}\text{Te}_{0.44} - \text{Ag}_{0.42}\text{Te}_{0.58}$

A thermogram has been obtained for an alloy having the same composition. It presents only one thermal effect at 605 K with a very small shoulder which indicates that this composition is very close to that of the experimental eutectic.

A vertical section corresponding to a constant of 0.42 molar content in Ag, has been studied using DTA and DSC and this was useful for determining the transitory ternary peritectic points with accuracy. This section is shown in Fig. 6. All the reactions of the subternary system are present in this section.

The invariant reactions occurring at 605, 633, 659 and 687 K present very energetic accidents on the DTA curves. The limits of the invariants and the path of the tie lines are not clearly seen on the DTA curves. However, some other experiments were performed at lower heating temperatures (e.g.  $5 \text{ K min}^{-1}$ ) and enable us to propose the experimental diagram presented in Fig. 6.

The position of the experimental eutectic point on the invariant appearing at 605 K has been checked by calculating the Tammann diagram.

#### DESCRIPTION OF THE POLYTHERMAL PROJECTION

Three isoplethal sections and the  $\text{Sb}_{0.4}\text{Te}_{0.6} - \text{Ag}_{0.666}\text{Te}_{0.333}$  section have been studied and are described. The polythermal projection of the liquidus lines was determined. This projection is shown in Fig. 7. Four ternary

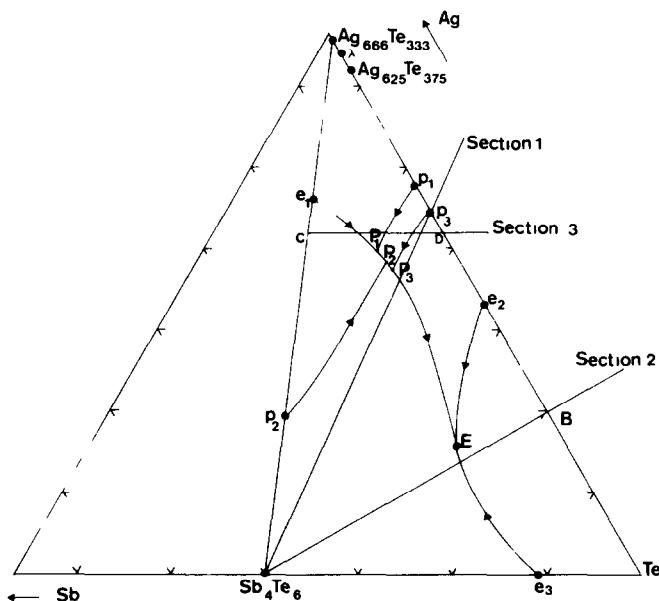
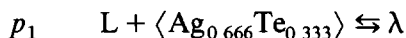
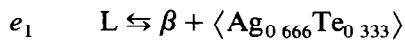

Fig 7 Polythermal projection of the  $\text{Ag}_2\text{Te}-\text{Sb}_2\text{Te}_3-\text{Te}$  system

invariants were observed. At 687 K, a first reaction is observed. It is a transitory peritectic section due to the binary eutectic and peritectic points  $e_1$  and  $p_1$ .



Two other reactions (659 and 633 K) of transitory peritectic type were obtained. The origin is the decomposition of the two  $\beta$  and  $\lambda$  phases. Finally, the ternary eutectic reaction appears at 605 K. The valley from the eutectic  $e_1$  in the section  $\text{Sb}_{0.4}\text{Te}_{0.6}-\text{Ag}_2\text{Te}$  cuts across the peritectic line  $p_1$  and  $p_3$  in the section  $\text{Ag}-\text{Te}$  and then across the peritectic point  $p_2$  in the section  $\text{Sb}_{0.4}\text{Te}_{0.6}-\text{Ag}_{0.666}\text{Te}_{0.333}$ . Thus, three peritectic transitory points can be observed on the projection.

## CONCLUSION

The ternary system  $\text{Ag}_2\text{Te}-\text{Sb}_2\text{Te}_3-\text{Te}$  has been studied. Several ternary transitions have been observed in the system which can be explained by the peritectic fusion of the compound and by the relative complexity of the binary system  $\text{Ag}-\text{Te}$ . The position of the eutectic ternary point has been calculated. The temperatures and positions of the invariant reactions have been determined, and have been related to the binary invariants.



## REFERENCES

- 1 J H Wernick and K E Benson, *J Phys Chem Solids*, 3 (1957) 157
- 2 R W Armstrong, J W Faust and W A Tiller, *J Appl Phys*, 31 (1960) 1954
- 3 D Gochev, St Decheva, St Dimitrova and G Hristakudis, *Bull J Phys*, 7 (1980) 279
- 4 J Olivier-Fourcade, L Izghouti, E Philippot and M Maurin, *Rev Chim Miner*, 20 (1983) 186
- 5 H Fay and H E Ashley, *Am Chem J*, 27 (1902) 95
- 6 H Pelabon, *Compt Rend*, 142 (1906) 207
- 7 Y Kimata, *Mem Coll Sci Kyoto Univ*, 1 (1915) 115
- 8 N S Konstantianov and V I Smironow, *St Petersburg Politekh, Inst Imp Petra Velik*, 23 (1915) 713
- 9 H Endo, *Science Rept Tohoku Univ*, 16 (1927) 213
- 10 M Hansen, *Constitution of Binary Alloys*, 2nd edn, 1958, p 1178
- 11 N Kh Abrikosov, L V Poretskaya and I P Ivanova, *Russ J Inorg Chem*, 4 (1959) 1163
- 12 B Legendre, J R Didry and S Bordas, *Thermochim Acta*, 197 (1986) 239
- 13 B Legendre, Y Feutelais and J R Didry, *J Therm Anal*, in press
- 14 B Legendre, Y Feutelais and J R Didry, *J Therm Anal*, (to be published)
- 15 F C Kracek, J Ksanda and L J Cabri, *Am Mineral*, 51 (1966) 14
- 16 B Legendre and C Souleau, *Bull Soc Chim Fr*, 5-6 (1980) 197
- 17 R M Marin, G Brun and J C Tedenac, *J Mater Sci*, 20 (1985) 730
- 18 B Legendre and C Souleau, *Bull Soc Chim Fr*, 2 (1972) 473